

SHARP CORPORATION

OSAKA, JAPAN

SPECIFICATION FOR LCD DISPLAY

MODEL NO. : 4L-U4E

BRAND NAME: SHARP

CUSTOMER: S. E. C

COUNTRY: U. S. A

JUN., 20, 1994
 DATE

R. Aoyagi
 SIGNATURE (R. Aoyagi)
 Department General Manager
 Product Quality Assurance
 Department
 LCD Visual Systems Division
 TV and Video Systems Group

SHARP CORPORATION

General Specifications for LCD Display Unit

Model : 4L-U4E

4 inch Color LCD Display Unit is suited for environmental conditions as for
Temperature -10 ~ +60 °C
Relative humidity ≤ 90%
Air pressure 795mmHg to 380mmHg

1. Test Condition

Unless otherwise specified, test and measurements are made under normal condition as follows

Normal temperature 15°C ~ 35°C
Normal relative humidity 45% ~ 75%
Normal air pressure 645mmHg ~ 795mmHg

- 2. Input signal Video signal(NTSC) Analog RGB
3. Power source DC 8.0V
4. Power consumption 4.3W (At DC 8.0V)
5. Viewing Area Diagonal 100.9mm Width 80.7mm Height 60.6mm
6. Appropriate Viewing angle 6 o'clock/12 o'clock switchable
7. Dimensions (Approx.) 112.5(W) x 96.5(H) x 35.9(D) mm
8. Weight (Approx.) 250g±10%
9. LCD display panel Active Matrix (a-Si TFT) 89,622 Dots (383H x 234V) Delta arrangement
10. Back light Cold Cathode Fluorescent Tube (W-Shape type)
11. Semiconductors (except LCD panel) ICs 5 pcs Transistors 14 pcs Diodes 11 pcs
12. Standard Safety standard UL 1492 under consideration EMI standard FCC under consideration

13.External terminal
A connector

- A 1: H-SYNC Output
 - A 2: V-SYNC Output
 - A 3: +5V Output
 - A 4: Left/Right Reverse Scanning(note 1)
 - A 5: Up/Down Reverse Scanning(note 1)
 - A 6: Color Control
 - A 7: Brightness Control
 - A 8: Tint Control
 - A 9: Dimming
 - A10: GND
 - A11: Video Input
 - A12: GND
 - A13: R Signal Input
 - A14: GND
 - A15: G Signal Input
 - A16: GND
 - A17: B Signal Input
 - A18: GND
 - A19: Vs Input
 - A20: Super Impose(note 2)
 - A21: N.C
 - A22: C-Sync Input
 - A23: GND
 - A24: GND(for Signal Circuit)
 - A25: +8V Input(for Signal Circuit)
 - A26: +8V Input(for Inverter)
 - A27: +8V Input(for Inverter)
 - A28: GND(for Inverter)
- Connector manufacturer: Molex
Connector name: 52207-2817

note 1		6 o'clock	12 o'clock
	A 4	Open	GND
	A 5	Open	GND
note 2		Normal	Super Impose
	A20	Open	GND

SHARP CORPORATION
Engineering Specifications for LCD Display Unit

Model : 4L-U4E

	Nominal	Limit
1. General		
1) Power voltage	DC 8V	7.5-8.5V
2) Operating temperature range	25°C	-10-60°C
3) Storage temperature range		-30-85°C
4) Power consumption(DC 8.0V Nominal)		4.3%±15%
2. Video output characteristics		
1) Video output (Standard color bars signal, at tint, color, bright-VR center)	4.5Vp-p	4.5±0.2Vp-p
2) Video fidelity(at 100kHz standard)		
1 MHz	2.0dB	0-4.0dB
2 MHz	-2.0dB	-5.0-1.0dB
3 MHz	-20.0dB	-24.0--15.0dB
3.5MHz	-25.0dB	-32.0--18.0dB
3. Picture quality		
1) Resolution (at ITC pattern)		
Horizontal center	170 lines	150 lines min.
corner	170 lines	150 lines min.
Vertical center	190 lines	170 lines min.
corner	190 lines	170 lines min.
2) Step response		
rising time		500nsec. max.
preshoot		35% max.
overshoot		20% max.
4. ACC characteristics		
ACC(at chroma output level -6dB)		0dB

	Nominal	Limit
5. Chroma		
1) Color Control range(for information only)		
2) Tint control range(for information only)		4dB min.
To green	30°	15° min.
To purple		15° min.
3) Tint stability(for information only)		
Tint drift		12° max.
Tint shift		12° max.
4) Color killer	-28dB	-18dB max.
6. Liquid crystal display		
1) Response time (at 25V)		60msec. max.
2) Brightness (reference)	230cd/m ²	160cd/m ² min.
(at 25°C, after warming for 30min.)		
3) Contrast (center best point)		1:50 min.
4) Viewing angle range(at contrast 1:10 minimum) 6 o'clock		
Left/Right		45°/45° min.
Up /Down		10°/30° min.
5) Dimming Range(Brightness)		100%-15% max.
7. Input signal requirement		
1) Composite video signal(standard signal:luminance order color bar signal with 100% white peak level)		
Input level	1.0Vp-p	1.0±0.1Vp-p
Input impedance		75Ω±5%
2) RGB Video signal		
Input level	0.7Vp-p	0.7±0.1Vp-p
Input impedance		75Ω±5%
3) Ys signal(A19 terminal)		
Input level		L: 0-0.8V H: 3.5-5.0V
Input impedance		10kΩ min.
4) Composite sync. signal(RGB signal input)		
Input level	TTL level (negative polarity)	
Horizontal frequency		15.734±200Hz
vertical frequency		60Hz±5Hz

5) Other input		Nominal		Limit
Terminal#	Terminal Name	Min.	Typ.	Max.
A9	Dimming	2.3V	2.3V	4.6V
A7	Brightness control	1.0V	2.9V	3.9V
A6	Color control	0.6V	2.2V	3.8V
A8	Tint control	2.0V	3.1V	3.5V

8. Output signal requirement

+5V output(A3 terminal)			
Output voltage range			5V±10%
maximum output current			10mA Max.
H-Sync Output(A1 terminal)		Typ.	
Output level		5.0V	
V-Sync Output(A2 terminal)		Typ.	
Output level		5.0V	

9. Signal input timing(H-sync:micro second,V-sync:#of lines)

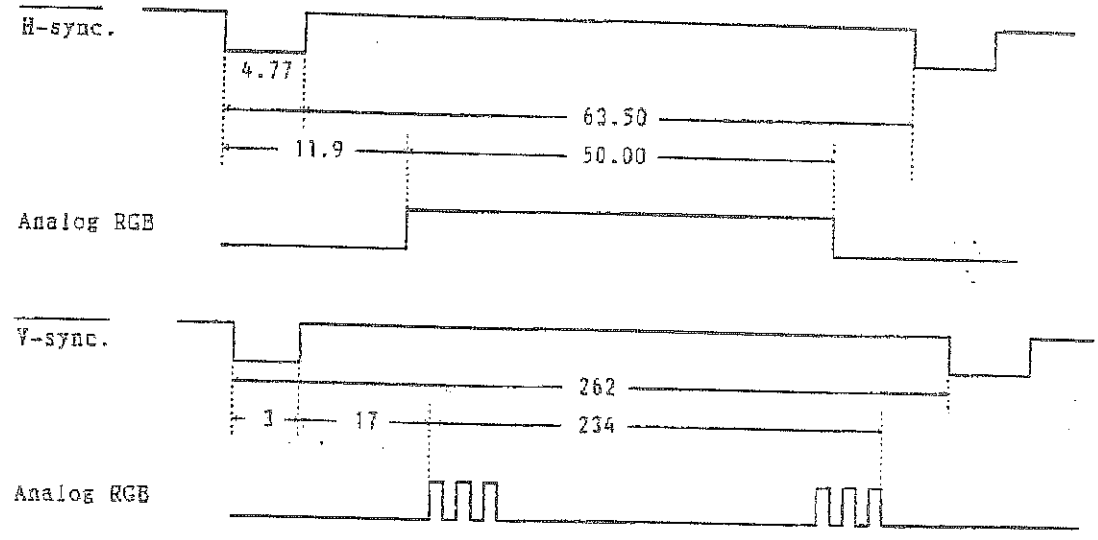

DE-133

RELIABILITY TEST

MODEL : 4L - U 4 E

It is required that LCD Display unit should be designed to comply with all the following reliability test.

1. Drop test

Drop off the carton, which includes 50 pcs/units inside, against the floor with 1 corner, 3 edges and 6 surfaces from the height of 60 cm.

The floor should be flat surface with horizontal position and made of concrete, rock, steel plate or equivalent.

After drop test the unit should have no safety hazard and operate as normal usage without any damage.

2. Vibration test

1) Conduct the following vibration test with the carton, which includes 50 pcs/units inside, and should operate as normal usage without any damage after this test.

- Frequency : 5~50(Hz)
- 1 cycle period : 3 minutes(back and force)
- Acceleration : 1.5 G each(X,Y,Z)
- Securement : Banding
- Time : Up/Down 60 minutes
- : Forward/Back 15 minutes
- : Right/Left 15 minutes

2) Endurance vibration test

Conduct the following vibration test with the chassis unit and should operate as normal usage without any damage after this test.

- Frequency : 10~200(Hz)
- Acceleration : 3 G
- 1 cycle period : 15 minutes
- Securement : Screw
- Time : Up/Down 4 hours
- : Forward/Back 2 hours
- : Right/Left 2 hours

3. Pressure reduction test
Set up the unit in the pressure reduction chamber and reduce the air pressure gradually from the normal pressure to 510hpa (380mmHg) which is equivalent to 5,000m height.
there should have no damage to turn on the unit with 10% increased power voltage for 30 minutes and repeat power on and off for 3 times quickly.
4. High temperature storage(without power)
Keep the unit in 85 $\text{\textcircled{C}}$ temperature chamber for 72 hours without power.
Take out the unit to make it normal temperature and make sure that the unit has no safety hazard and operate as normal usage without any damage.
5. Low temperature storage(without power)
Keep the unit in -30 $\text{\textcircled{C}}$ temperature chamber for 72 hours without power.
Take out the unit to make it normal temperature and make sure that the unit has no safety hazard and operate as normal usage without any damage.
6. Humidity test(with power)
Operate the unit in 40 $\text{\textcircled{C}}$ temperature and 90 ~ 95% humidity chamber for 90 hours with $\pm 10\%$ increased power.
Make sure that the unit has no safety hazard and operate as normal usage without any damage.
7. High temperature test(with power)
Operate the unit for 72 hours with $\pm 10\%$ increased power after keeping the unit in 60 $\text{\textcircled{C}}$ temperature chamber for 2 hours.
Make sure that the unit has no safety hazard and operate as normal usage without any damage.
8. Low temperature test(with power)
Operate the unit for 72 hours with $\pm 10\%$ increased power after keeping the unit in -10 $\text{\textcircled{C}}$ temperature chamber for 2 hours.
Make sure that the unit has no safety hazard and operate as normal usage without any damage.

9. Electrostatic discharge test

Discharge DC 8kV under operating. DC 15kV under non operating to chassis angle for

10 times of 1 second interval with 5000 200pF probe.

Under operating : The unit should operate without any trouble during operation.

Under non operating : No component damage

exception : This will not be applied when the unit recovered from the trouble after powering it off and then on. This test will not be applied to In/Out connector terminal.

10. Thermal shock test

Keep the unit in the following Temperature chamber without and make sure that unit has no safety hazard and operate as normal usage without any damage.

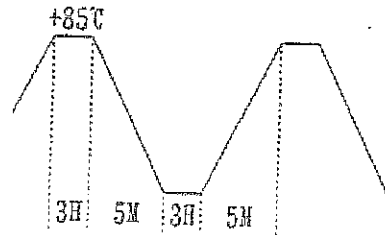

#of Cycle : 10 cycle

0E-11C

4L-U4 Electrical Interface Requirements

The following describes electrical requirements and precautions for the 4L-U4 LCD Display.

1. Using Composite Video Input

- Use connector pins A11 and A12 (GND) for composite video input.
- Set pin A19 (Ys signal) to Low (GND) level, or leave it open.

2. Using Analog RGB Inputs

- Use connector A pins A13 - A18, A22, and A23 for analog RGB input.
- For horizontal and vertical synchronization, apply a composite H/V sync. signal (Negative polarity TTL level) to pin A22.
When separate H. and V. synchronization signals are desired, consult us.
- A high level (5V) signal should be applied to the Ys signal input (pin A19).

3. Using Superimposed Video Signals

- The composite and RGB video signals should be synchronized with each other.
- Use connector A pins A13 through A18 for RGB video inputs, and pins A11 and A12 for composite video inputs.
- Set pin A20 (S/I ON signal) to low (GND) level to make the composite synchronization signal active.
- RGB is selected when the Ys (pin A19) is set high.

4. Controlling Color, Tint, and Brightness (pins A6, A8, and A7)

- The following voltage ranges are typically recommended for color, Tint, and brightness control:

	Pin	Center Voltage	Voltage range
Color	A6	2.2V	0.6 - 3.8V
Tint	A8	3.1V	2.0 - 3.5V
Brightness	A7	2.9V	1.0 - 3.9V

5. Dimmer Control Voltage

- The voltage applied to pin A9 should range from 2.3 to 4.6V volts.
(Maximum brightness is at 2.3V and minimum brightness at 4.6V [around 15% of the maximum brightness]).

6. RGB signal Timing Chart (Reference)

- A full-screen image is obtained with the following timing:

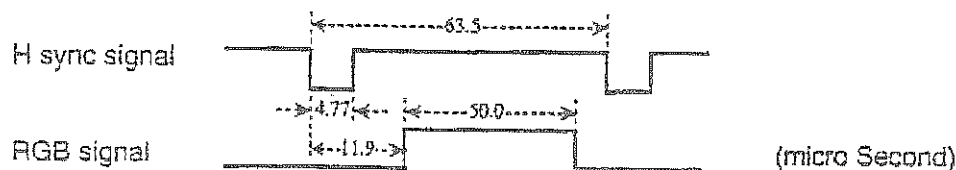

7. Connector Pin Assignments.

A 1	H-OUT	Horizontal sync. pulse output	Negative polarity, 5.0Vpp
A 2	V-OUT	Vertical sync. pulse output	Negative polarity, 5.0Vpp
A 3	-5V OUT	-5VDC output	Used for Brightness Color Tint Dimmer control
A 4	LRVC	Left/Right switch	Reversed at Low Level
A 5	URVC	Up/Down switch	Reversed at Low Level
A 6	COLOR	Color control	DC control
A 7	BRIGHT	Brightness control	DC control
A 8	TINT	Tint control	DC control
A 9	DIMMER	Dimming control	DC control
A10	GND		
A11	VIDEO IN	Composite video signal input	1±0.2Vpp (75Ω termination), positive
A12	GND		
A13	R IN	R input	0.7±0.1Vpp (75Ω termination)
A14	GND		
A15	G IN	G input	0.7±0.1Vpp (75Ω termination)
A16	GND		
A17	B IN	B input	0.7±0.1Vpp (75Ω termination)
A18	GND		
A19	Ys IN	Ys signal input	Low level (0 to 0.8 V) High level (3.5 to 5 V)
A20	S/E ON	Superimpose Active signal input	Superimpose mode at Low level
A21	N.C.		
A22	CSYNC IN	Composite sync. signal input	Negative polarity TTL level
A23	GND		
A24	DC/DC GND		Supply ground for DC/DC circuit
A25	DC/DC 5V IN	5VDC input	Circuit power supply (approx. 150mA)
A26	DC/AC 3V IN	3VDC input	Power supply for DC/AC inverter
A27	DC/AC 5V IN	5VDC input	Power supply for DC/AC inverter (approx. 410mA)
A28	DC/AC GND		GND for DC/AC inverter

Connector:

Manufacturer: Molex

A connector : 52207-2817

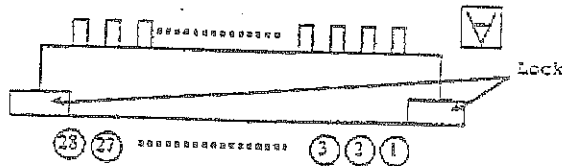

Contacts are configured upward.

8. Miscellaneous

- Supply Input

The 4L-U4 requires two separate $8 \pm 0.2V$ power supply systems for signal processing (pins A24, A25) and the DC/AC inverter (A26 - A29). Separate voltage regulators should be used for the two power supply systems as follows:

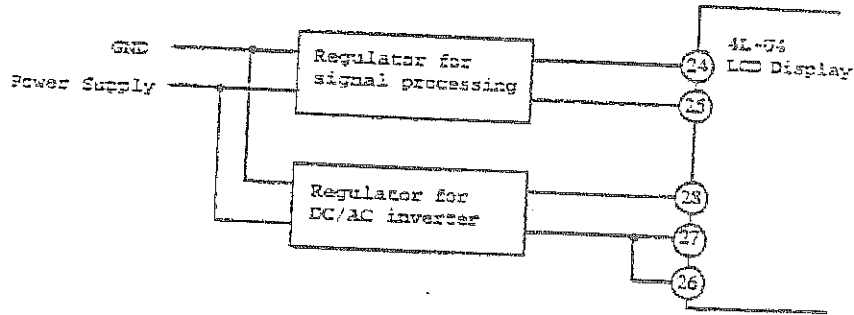

Connect the grounds for the two supply systems. Otherwise, display images may be disturbed by beat caused by supply ripple.

- Input signal timing

Do not activate control signals before the supply voltages have stabilized for the signal processing and inverter circuits. Otherwise, the circuit may be damaged by latchup.

- +5VDC output

The +5 VDC output at pin A3 may be used for brightness, color, tint, and dimmer adjustment. The current capacity is 10 mA max.

Note) The content of this information is subject to change without prior notice.

